

Illuminazione/ lighting

SEN

ASEN0991

Lampada con luce LED
LED light lamp



- Leggere le istruzioni prima di installare e utilizzare l'apparecchio.
- Conservare le istruzioni.
- L'installazione deve essere effettuata da personale qualificato.
- L'installazione deve avvenire nel rispetto delle norme vigenti nel paese.
- Se il cavo di alimentazione è danneggiato, va sostituito dal costruttore, dal suo servizio assistenza, oppure da persona/azienda autorizzata.
- Prima di iniziare il montaggio assicurarsi di TOGLIERE TENSIONE dall'impianto elettrico.
- Conservare l'imballo fino ad accertamento del buon funzionamento dell'articolo.



- Read the instructions before installing and using the device.
- Conserve the instructions.
- The installation has to be effected by trained personnel.
- The installation has to respect the valid standards.
- If the power cable is damaged, it has to be replaced by the supplier, by his customer service or by an authorized company /person.
- Before installing, please verify that the electric plant is not under tension.
- Conserve the package until you checked the articles functionality.

- Rifiuto speciale elettrico - Smaltire negli appositi centri di raccolta



- Electric special waste dispose in the relevant waste collector



MANUTENZIONE

Per la normale pulizia si consiglia di utilizzare detersivi di uso comune. Si sconsiglia l'utilizzo di detersivi abrasivi, acidi e anticalcare.

NOTA

La ferramenta in dotazione permette il fissaggio su pareti in mattoni pieni o forati e in calcestruzzo. Per pareti in cartongesso è necessario rinforzare adeguatamente la zona interessata ed eventualmente adottare sistemi di fissaggio specifici.

DATI TECNICI
N° 1 LED - 3000K -24V
10 W - 200/240V - CE F

DATI TECNICI USA
N° 1 LED - 3000K -24V
10 W - 110V - CE F

MAINTENANCE

For normal cleaning use common detergents. Do not use either abrasive detergents or solvents, acids and anti limestone.

NOTE

The assembly material supplied allows the installation on solid and hollow brick walls and on concrete walls. For plasterboard walls it is necessary to reinforce adequately the area concerned and to adopt specific fixing systems if necessary.

DATI TECNICI
N° 1 LED - 3000K - 24V
10 W - 200/240V - CE F

DATI TECNICI USA
N° 1 LED - 3000K - 24V
10 W - 110V - CE F

CONTENUTO DELLA CONFEZIONE
PACKAGE CONTENTS

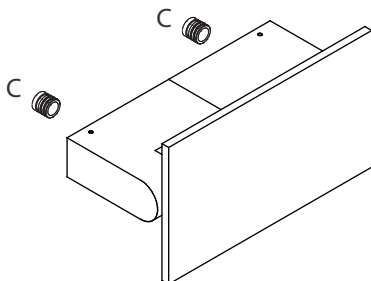

fissaggi / fixing



STRUMENTI
TOOLS

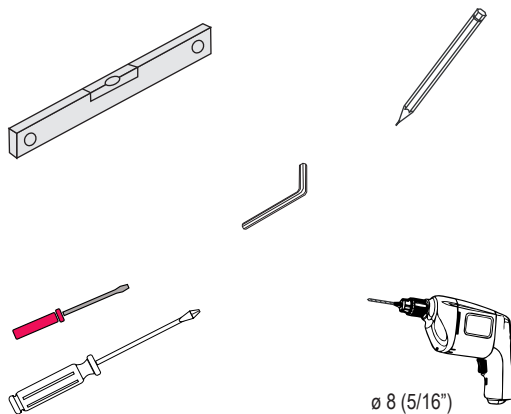

PREDISPOSIZIONE
PREDISPOSITION

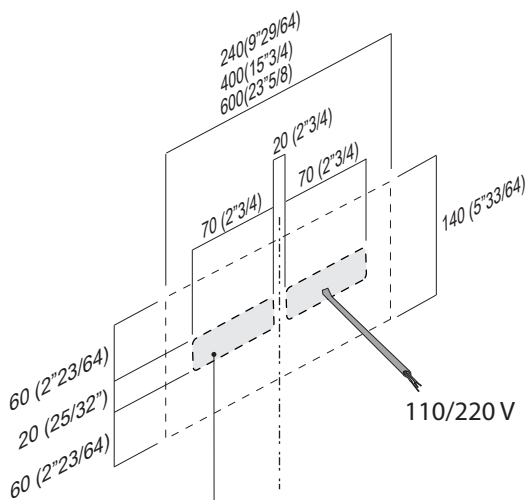

area attacco elettrico
electrical connection area

INSTALLATO
MOUNTED

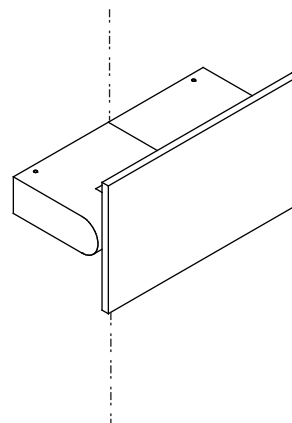

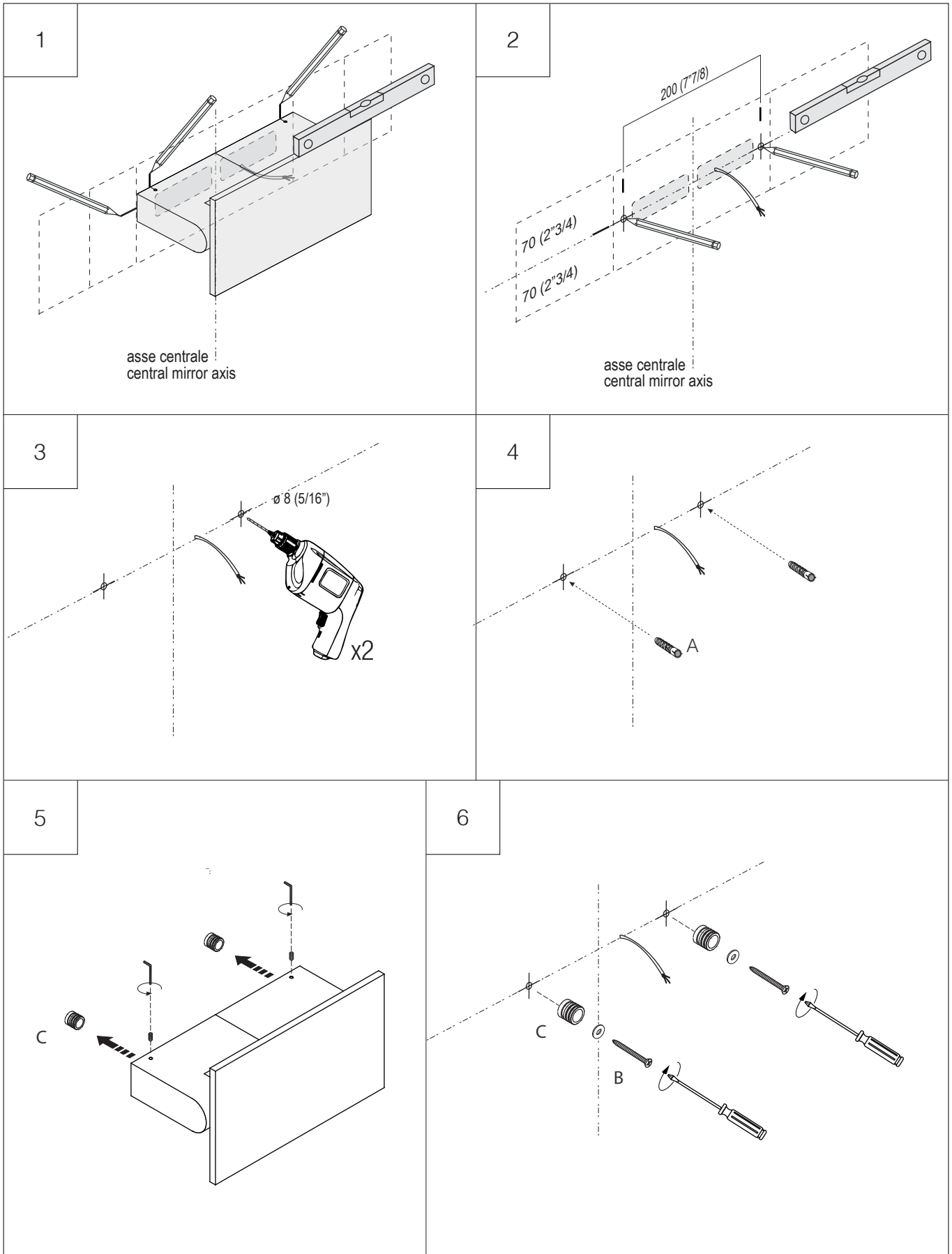

7

Collegare i cavi elettrici
Connect the electric cables

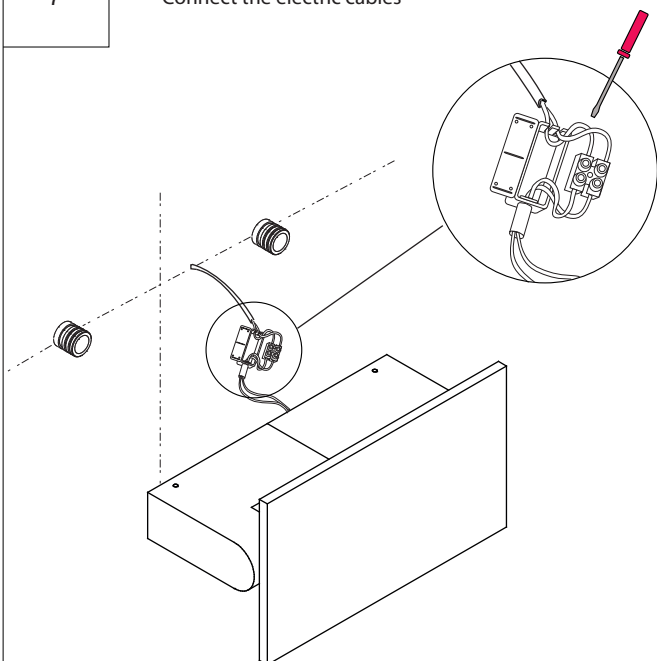

8

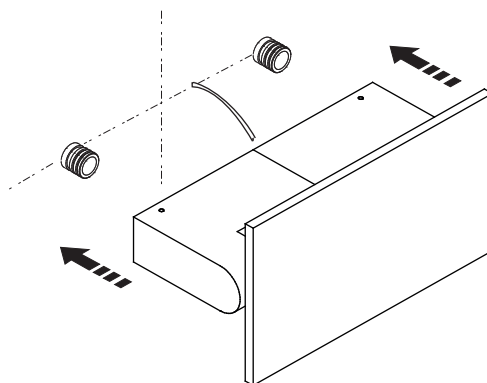

9

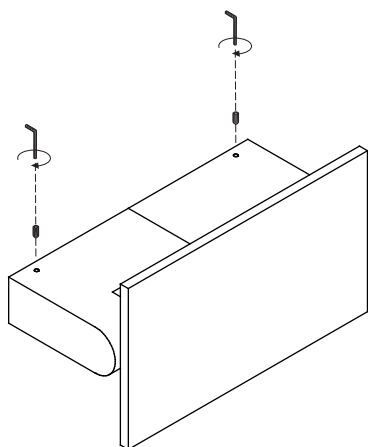

10

